

DB-BG Ground Floor

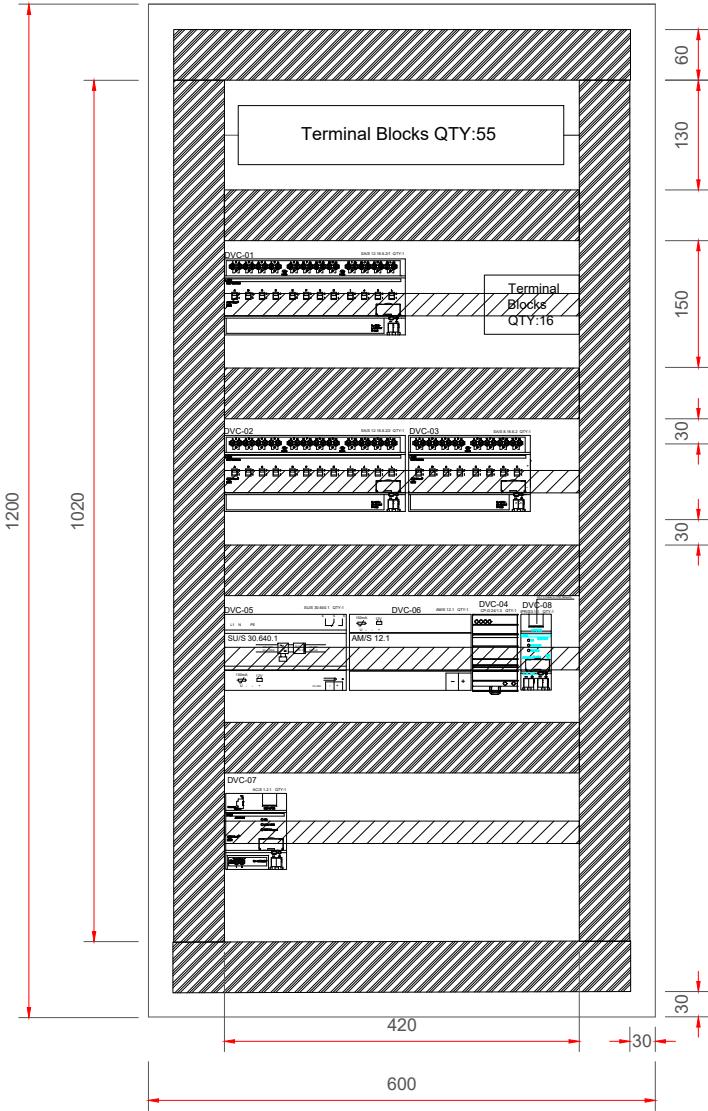

GENERAL NOTES:

System Integrator



OWNER:



CONSULTANT :



CONTRACTOR:



PROJECT TITLE:

HSBC Maadi Nile Coumich

DRAWING TITLE :

KNX PANEL SHOP DRAWINGS

DRAWING NUMBER :

DB-BG

PAGE: 1

DATE	REV.	PROJECT NO.	PAPER
October-2023	00	--	A4

PREPARED BY: _____ CHECKED BY: _____ APPROVED BY: _____

ENG. M.E. ENG. M.T. ENG. M.H.

DVC-01

SAS 12.16.6.2/1 QTY:1

ADD: 2.1.1



ABB
SAS 12.16.6.2



ABB I-bus®
KNX

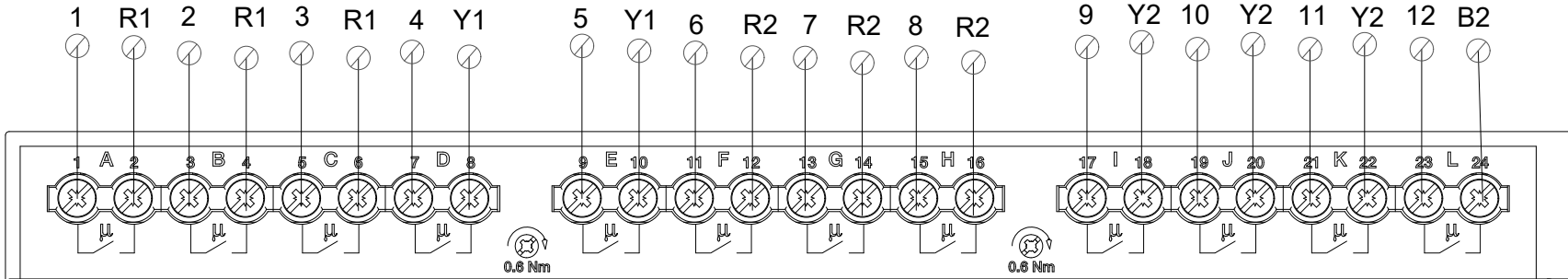

GENERAL NOTES:

System Integrator

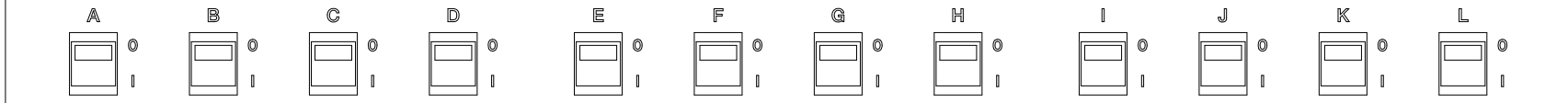
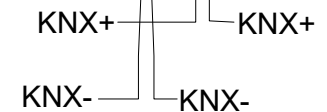
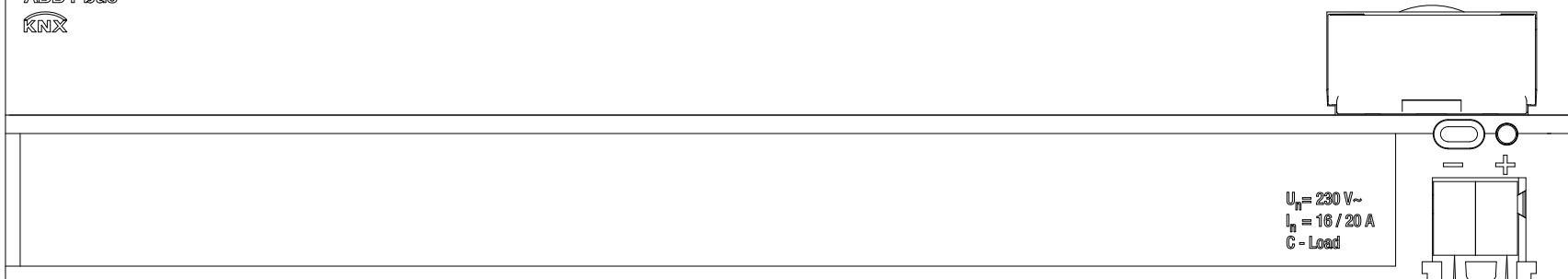
OWNER:

CONSULTANT:

CONTRACTOR:

PROJECT TITLE:
HSBC Maadi Nile Courch

DRAWING TITLE :
KNX PANEL SHOP DRAWINGS

DRAWING NUMBER :
DB-BG
PAGE: 2

DATE	REV.	PROJECT NO.	PAPER
October-2023	00	--	A4

DVC-02

SA/S 12.16.6.2/2 QTY:1

ADD: 2.1.2



ABB
SA/S 12.16.6.2



ABB I-bus®
KNX

$U_n = 230 V-$
 $I_n = 16 / 20 A$
C - Load

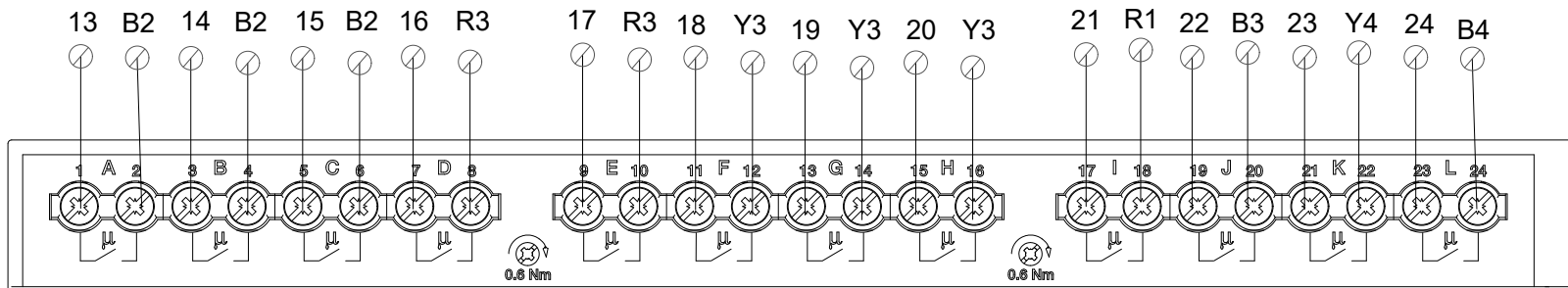

GENERAL NOTES:

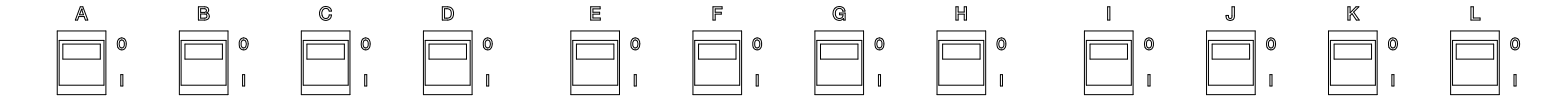
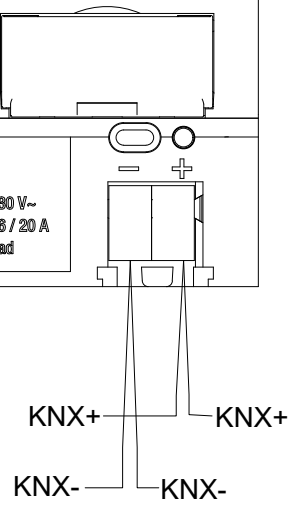
System Integrator

OWNER:

CONSULTANT:

CONTRACTOR:

PROJECT TITLE:
HSBC Maadi Nile Courmich

DRAWING TITLE :
KNX PANEL SHOP DRAWINGS

DRAWING NUMBER :
DB-BG
PAGE: 3

DATE	REV.	PROJECT NO.	PAPER
October-2023	00	--	A4

DVC-03

SA/S 8.16.6.2 QTY:1

ADD: 2.1.3

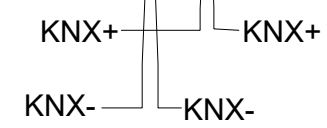
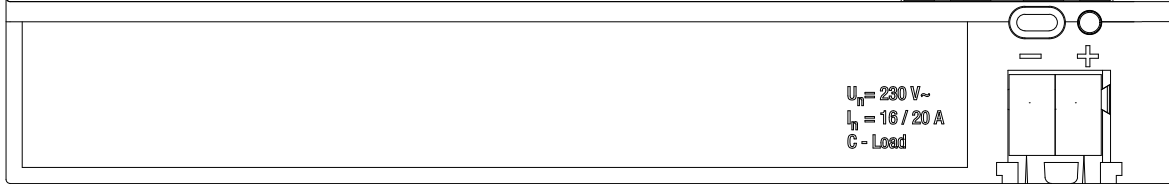
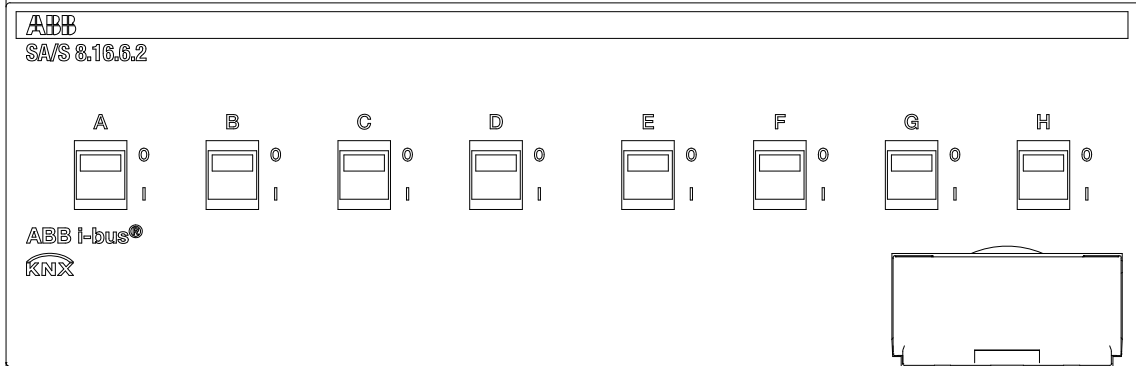
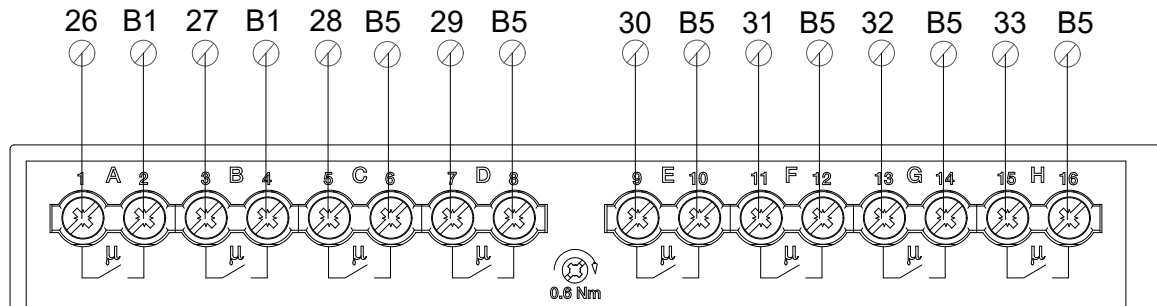

GENERAL NOTES:

System Integrator

OWNER:

CONSULTANT:



CONTRACTOR:

PROJECT TITLE:
 HSBC Maadi Nile Courmich

DRAWING TITLE :
 KNX PANEL SHOP DRAWINGS

DRAWING NUMBER :
 DB-BG
 PAGE: 4

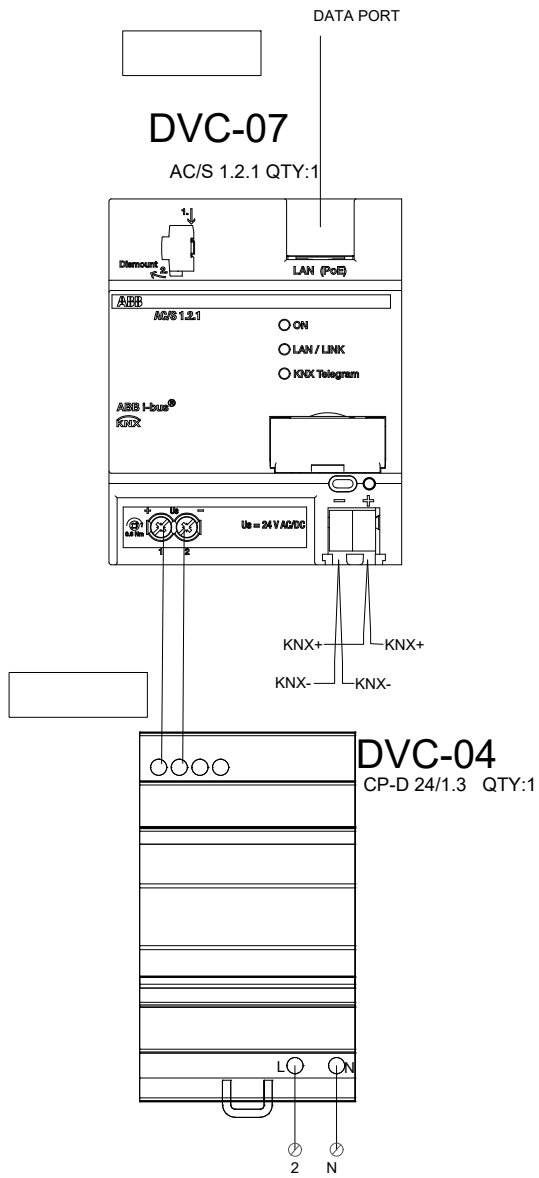
ENG. M.E	ENG. M.T	ENG. M.H
DATE	REV.	PROJECT NO.
October-2023	00	--
		PAPER
		A4



GENERAL NOTES:

System Integrator



OWNER:



CONSULTANT :



CONTRACTOR:



PROJECT TITLE:

HSBC Maadi Nile Courmich

DRAWING TITLE :

KNX PANEL SHOP DRAWINGS

DRAWING NUMBER :

DB-BG

PAGE: 5

PREPARED BY:		CHECKED BY:		APPROVED BY:	
ENG. M.E	ENG. M.T	ENG. M.T	ENG. M.H	ENG. M.H	ENG. M.H
DATE	REV.	PROJECT NO.	PAPER		
October-2023	00	--	A4		



SU/S 30.640.1

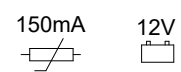
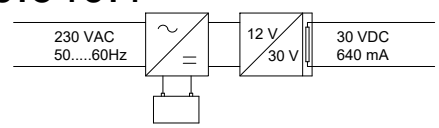

U

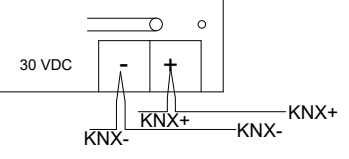

DVC-06

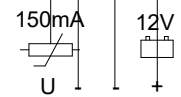

U

AM/S 12.1

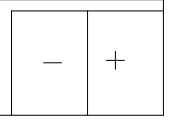

GENERAL NOTES:

System Integrator



OWNER:



CONSULTANT :



CONTRACTOR:



PROJECT TITLE:

HSBC Maadi Nile Courmich

DRAWING TITLE :

KNX PANEL SHOP DRAWINGS

DRAWING NUMBER :

DB-BG

PAGE: 6

PREPARED BY:		CHECKED BY:		APPROVED BY:	
ENG. M.E	ENG. M.T	ENG. M.T	ENG. M.H	ENG. M.H	
DATE	REV.	PROJECT NO.	PAPER		
October-2023	00	--	A4		

DATA PORT

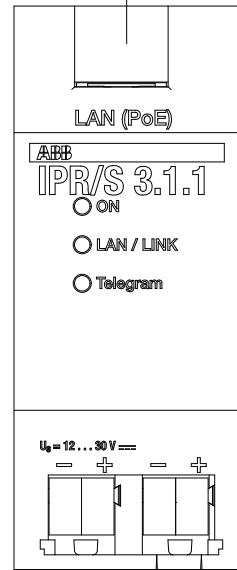

DVC-08

GENERAL NOTES:

System Integrator



OWNER:



CONSULTANT :



CONTRACTOR:



PROJECT TITLE:

HSBC Maadi Nile Courmich

DRAWING TITLE :

KNX PANEL SHOP DRAWINGS

DRAWING NUMBER :

DB-BG

PAGE: 7

PREPARED BY:	CHECKED BY:	APPROVED BY:	
ENG. M.E	ENG. M.T	ENG. M.H	
DATE	REV.	PROJECT NO.	PAPER
October-2023	00	--	A4

HSBC

GROUND FLOOR

DB-BG

33

NUMBER OF RETURNS CONTROLLED BY PRESENCE SENSOR ONLY / PIR & LIGHTING SWITCH / LIGHTING SWITCH ONLY	CIRCUIT COLOR	CIRCUIT NO.	RETURNS NO. FOR EACH CIRCUIT	LOCATION	NUMBER OF DALI LIGHTING FIXTURES (DALI DRIVER)	PRESENCE SENSOR	KEYPAD & TOUCH SCREEN	Actuator Address	Actuator Channel
33	R1	CT1	1	SIDE ENTRANCE		38	One TOUCH SCREEN IN ELEC ROOM G-143	DVC-01 2.1.1	A
			2	IT BUILT ROOM G-130					B
			3	IT BUILT ROOM G-130					C
			21	SIDE ENTRANCE PINS LIGHT					D
	Y1	CT2	4	IT Room G-152	E				
			5	Corridor G-153	F				
	B1	CT3	LIFE	IT RISER G-138	-				
			6	KITCHEN G-119	G				
	R2	CT4	7	CAFETERIA G-128	H				
			8	CAFETERIA G-128	I				
			9	FEMALE TOILET LOBBY	J				
	Y2	CT5	10	FEMALE TOILET G-136	K				
			11	JANITOR G-135	L				
			12	CORRIDOR G-139	A				
	B2	CT6	13	CORRIDOR G-139	B				
			14	CIRCULATION G-131	C				
			15	DISABLED TOILET G-148	D				
			16	Ops Scanning G-151	E				
	R3	CT7	17	Ops Scanning G-151	F				
			18	RECEPTION G-101	G				
	Y3	CT8	19	BALACONY 1ST FLOOR	H				
			20	CIRCULATION G-126	I				
			22	OUTDOOR CAFÉ	J				
	B3	CT9							
	Y4	CT11	23	PINS LIGHT BALACONY 1ST FLOOR	K				
	B4	CT12	24	PINS LIGHT RECEPTION	L				
	Y1	CT2	25	OUTDOOR TOTUMN SIGNAGE	H				
			26	BRANCH TOILET G-140	A				
	B1	CT3	27	BRANCH TOILET G-141	B				
			28	SPARE	C				
			29	SPARE	D				
			30	SPARE	E				
		31	SPARE	F					
		32	SPARE	G					

GENERAL NOTES:

System Integrator



OWNER:



CONSULTANT :



CONTRACTOR:



PROJECT TITLE:

HSBC Maadi Nile Courmich

DRAWING TITLE :

KNX PANEL SHOP DRAWINGS

DRAWING NUMBER :

DB-BG

PAGE: 9

PREPARED BY:	CHECKED BY:	APPROVED BY:
ENG. M.E	ENG. M.T	ENG. M.H
DATE	REV.	PROJECT NO. PAPER
October-2023	00	-- A4

EDB-BG Ground Floor

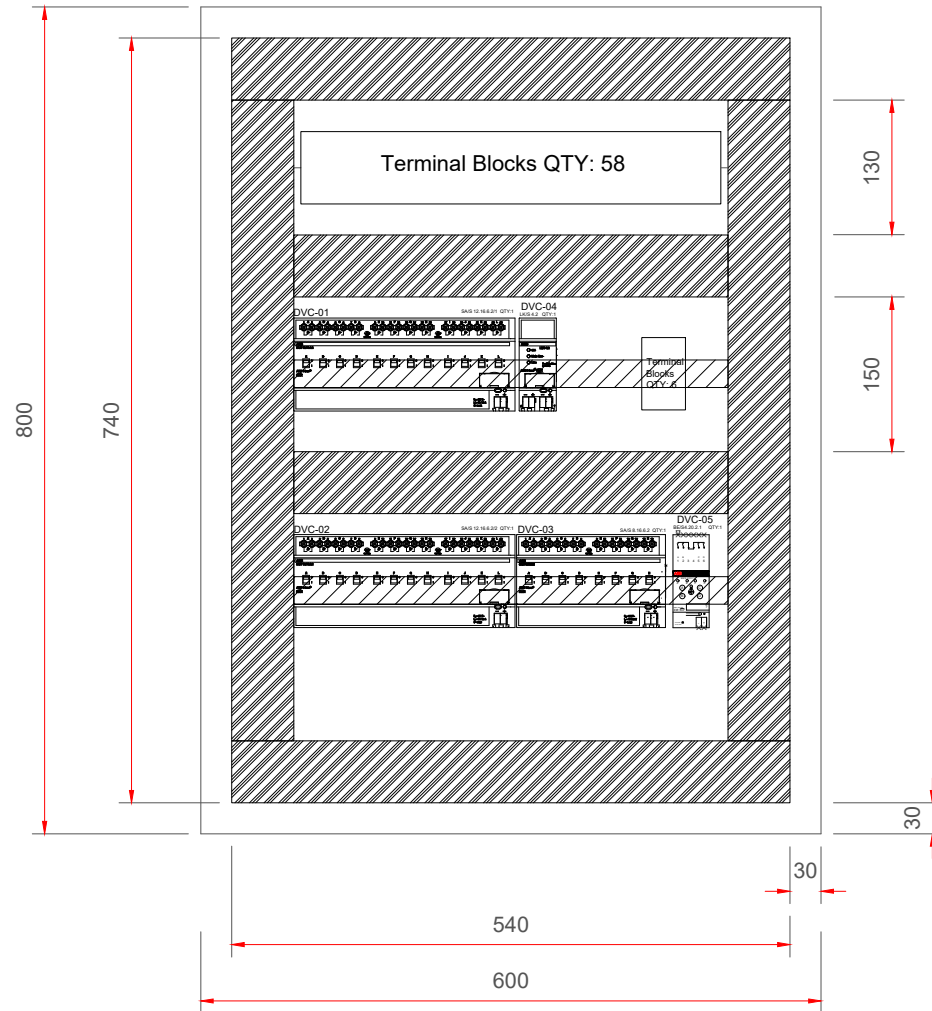

GENERAL NOTES:

System Integrator



OWNER:



CONSULTANT :



CONTRACTOR:



PROJECT TITLE:

HSBC Maadi Nile Courmich

DRAWING TITLE :

KNX PANEL SHOP DRAWINGS

DRAWING NUMBER :

EDB-BG

PAGE: 1

PREPARED BY:		CHECKED BY:		APPROVED BY:	
DATE	REV.	DATE	REV.	DATE	REV.
October-2023	00		--		A4

DVC-01

SAS 12.16.6.2/1 QTY:1

ADD: 2.1.4

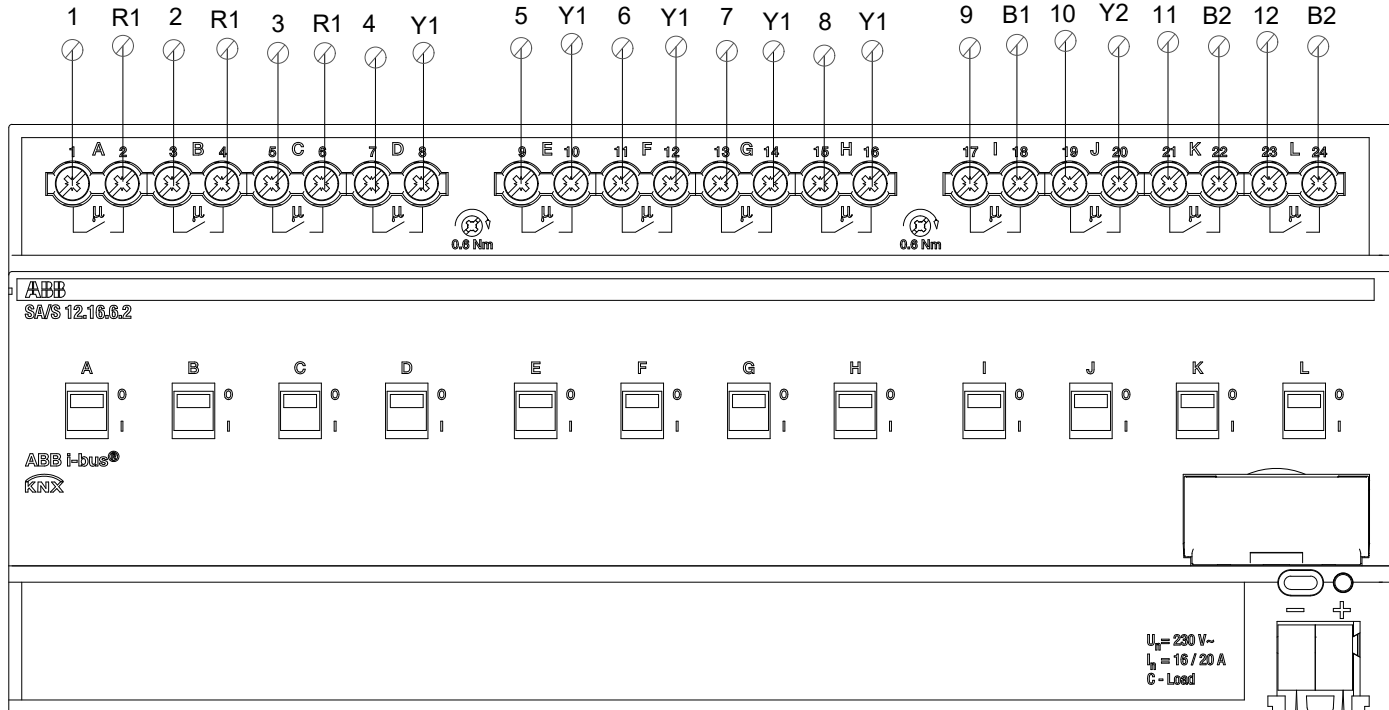

KNX+ KNX+
KNX- KNX-

GENERAL NOTES:

System Integrator



OWNER:



CONSULTANT:



CONTRACTOR:



PROJECT TITLE:

HSBC Maadi Nile Courmich

DRAWING TITLE :

KNX PANEL SHOP DRAWINGS

DRAWING NUMBER :

EDB-BG

PAGE: 2

ENG. M.T	ENG. SH.A	ENG. M.H
October-2023	00	--
DATE	REV.	PROJECT NO.
October-2023	00	--
		PAPER
		A3

DVC-02

SA/S 12.16.6.2/2 QTY:1

ADD: 2.1.5

GENERAL NOTES:



ABB
SA/S 12.16.6.2



ABB i-bus®
KNX

$U_n = 230\text{ V-}$
 $I_n = 16 / 20\text{ A}$
 C-Load

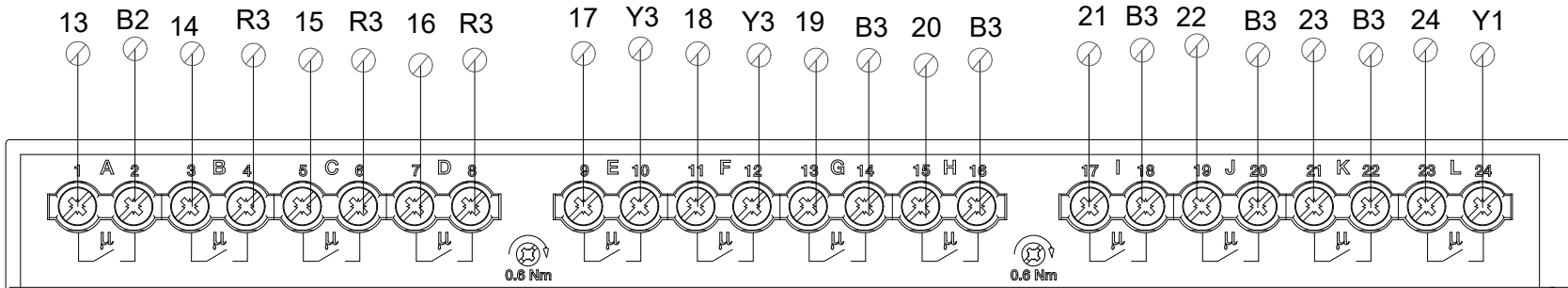

System Integrator

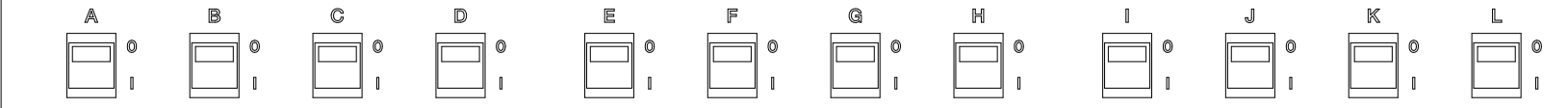
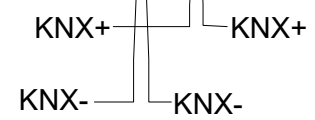

OWNER:



CONSULTANT:



CONTRACTOR:



PROJECT TITLE:

HSBC Maadi Nile Courmich

DRAWING TITLE :

KNX PANEL SHOP DRAWINGS

DRAWING NUMBER :

EDB-BG

PAGE: 3

DATE	REV.	PROJECT NO.	PAPER
October-2023	00	--	A4

DVC-03

SA/S 8.16.6.2 QTY:1

ADD: 2.1.6

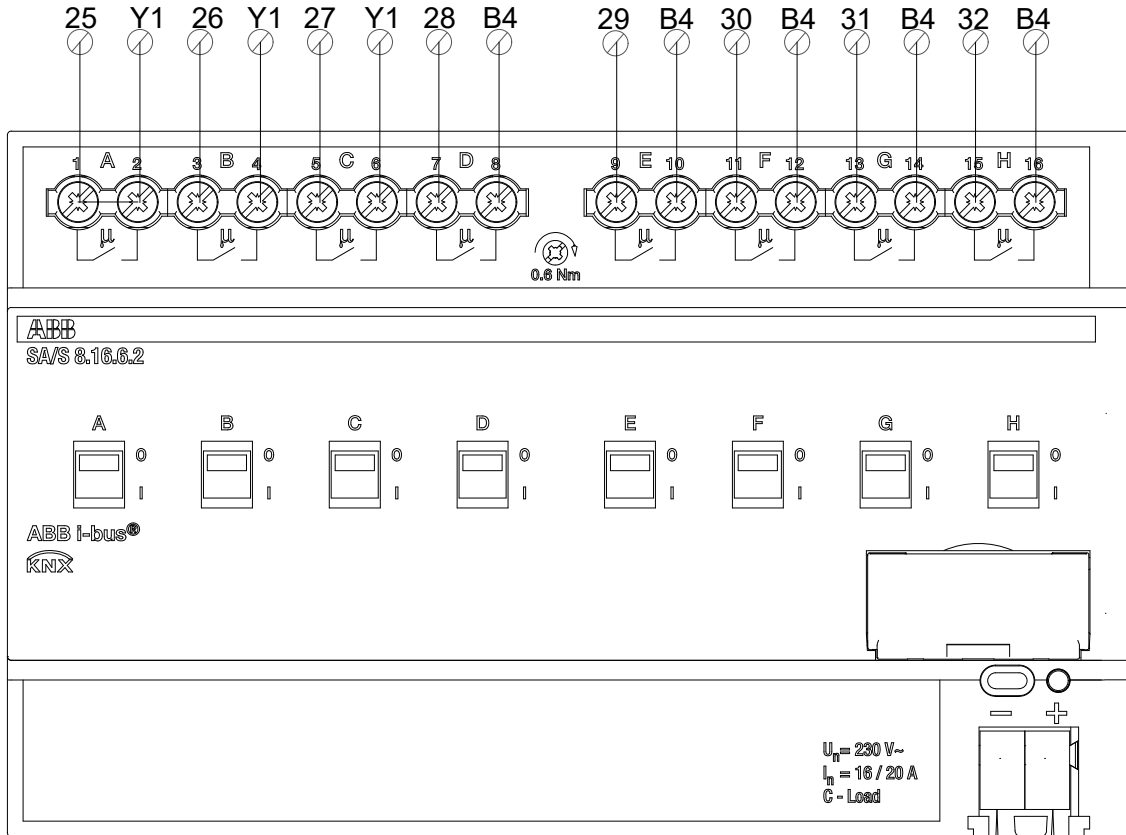

GENERAL NOTES:

System Integrator



OWNER:



CONSULTANT:



CONTRACTOR:



PROJECT TITLE:

HSBC Maadi Nile Courmich

DRAWING TITLE :

KNX PANEL SHOP DRAWINGS

DRAWING NUMBER :

EDB-BG

PAGE: 4

DATE	REV.	PROJECT NO.	PAPER
October-2023	00	--	A4

PREPARED BY: _____ CHECKED BY: _____ APPROVED BY: _____

ENG. M.E. ENG. M.T. ENG. M.H.

ADD: 2.1.0

DVC-04

LK/S 4.2

ABB

- ON
- Main Line
- Line

1= Main Line
2= Line

$U_0 = 12 \dots 30 \text{ V} \text{ ---}$

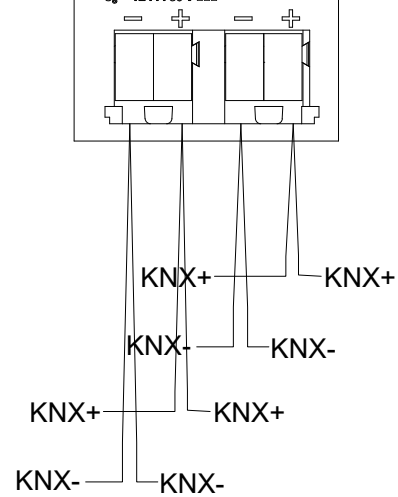

GENERAL NOTES:

System Integrator



OWNER:



CONSULTANT :



CONTRACTOR:



PROJECT TITLE:

HSBC Maadi Nile Courmich

DRAWING TITLE :

KNX PANEL SHOP DRAWINGS

DRAWING NUMBER :

EDB-BG

PAGE: 5

PREPARED BY:	CHECKED BY:	APPROVED BY:	
ENG. M.E	ENG. M.T	ENG. M.H	
DATE	REV.	PROJECT NO.	PAPER
October-2023	00	--	A4

ADD: 2.1.8

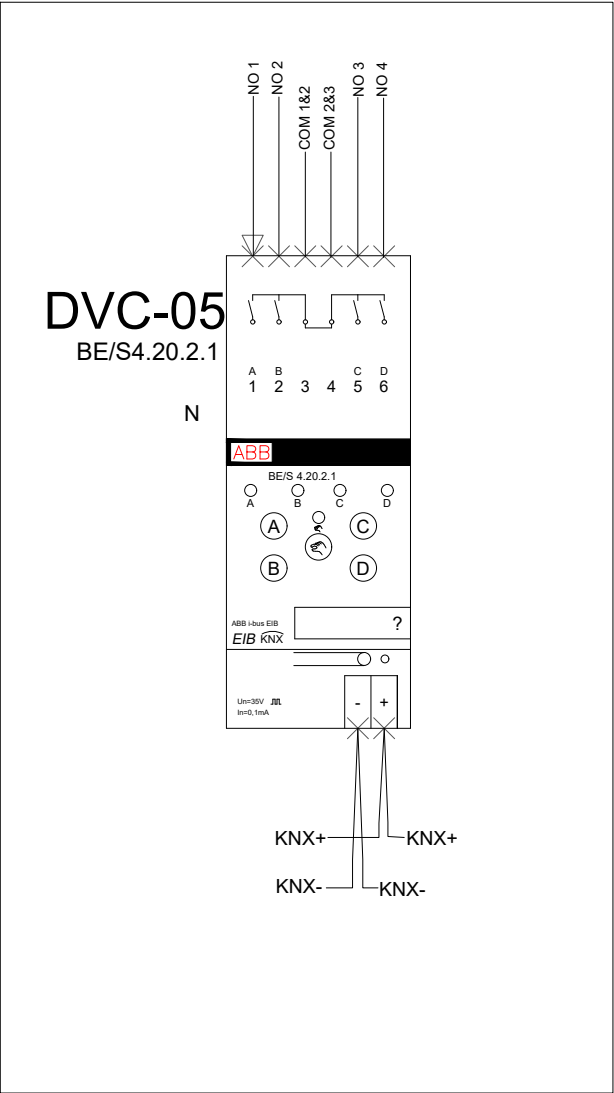

GENERAL NOTES:

System Integrator



OWNER:



CONSULTANT :



CONTRACTOR:



PROJECT TITLE:
HSBC Maadi Nile Courmich

DRAWING TITLE :
KNX PANEL SHOP DRAWINGS

DRAWING NUMBER :
EDB-BG
PAGE: 6

PREPARED BY:		CHECKED BY:		APPROVED BY:	
DATE	REV.	DATE	REV.	DATE	REV.
October-2023	00				A4

HSBC

GROUND FLOOR

	NUMBER OF RETURNS CONTROLLED BY PRESENCE SENSOR ONLY / PIR & LIGHTING SWITCH / LIGHTING SWITCH ONLY	CIRCUIT COLOR	CIRCUIT NO.	RETURNS NO. FOR EACH CIRCUIT	LOCATION	NUMBER OF DALI LIGHTING FIXTURES (DALI DRIVER)	PRESENCE SENSOR	KEYPAD & TOUCH SCREEN	Actuator Address	Actuator Channel
EDB-BG	32	R1	CT1	1	SIDE ENTRANCE		38	One TOUCH SCREEN IN ELEC ROOM G-143	DVC-01 2.1.4	A
				2	IT BUILT ROOM G-130	B				
				3	IT BUILT ROOM G-130	C				
		Y1	CT2	4	ELEC ROOM G-143	D				
				5	STAIRS LOBBY G-142	E				
				6	Storage G-132	F				
				7	FEMALE TOILET LOBBY	G				
		B1	CT3	8	FEMALE TOILET G-136	H				
				9	STAIRS G-146	I				
		Y2	CT5	10	CIRCULATION G-126	J				
				11	CORRIDOR G-139	K				
		B2	CT6	12	CORRIDOR G-139	L				
				13	CIRCULATION G-131	A				
		R3	CT7	14	KITCHEN G-119	B				
				15	CAFETERIA G-128	C				
		Y3	CT8	16	CAFETERIA G-128	D				
				17	RECEPTION G-101	E				
				18	BALACONY 1ST FLOOR	F				
				19	Ops Scanning G-151	G				
		B3	CT9	20	Ops Scanning G-151	H				
				21	IT Room G-152	I				
				22	Corridor G-153	J				
				23	NEW ELEC ROOM	K				
		Y1	CT2	24	Embossing Room G-133	L				
				25	Dispatch Room G-150	A				
				26	BRANCH TOILET G-140	B				
				27	BRANCH TOILET G-141	C				
				28	SPARE	D				
				29	SPARE	E				
				30	SPARE	F				
				31	SPARE	G				
				32	SPARE	H				

GENERAL NOTES:

System Integrator



OWNER:



CONSULTANT :



CONTRACTOR:



PROJECT TITLE:

HSBC Maadi Nile Courmich

DRAWING TITLE :

KNX PANEL SHOP DRAWINGS

DRAWING NUMBER :

EDB-BG

PAGE: 8

PREPARED BY:	CHECKED BY:	APPROVED BY:	
ENG. M.E	ENG. M.T	ENG. M.H	
DATE	REV.	PROJECT NO.	PAPER
October-2023	00	--	A4

DB-AG Ground Floor

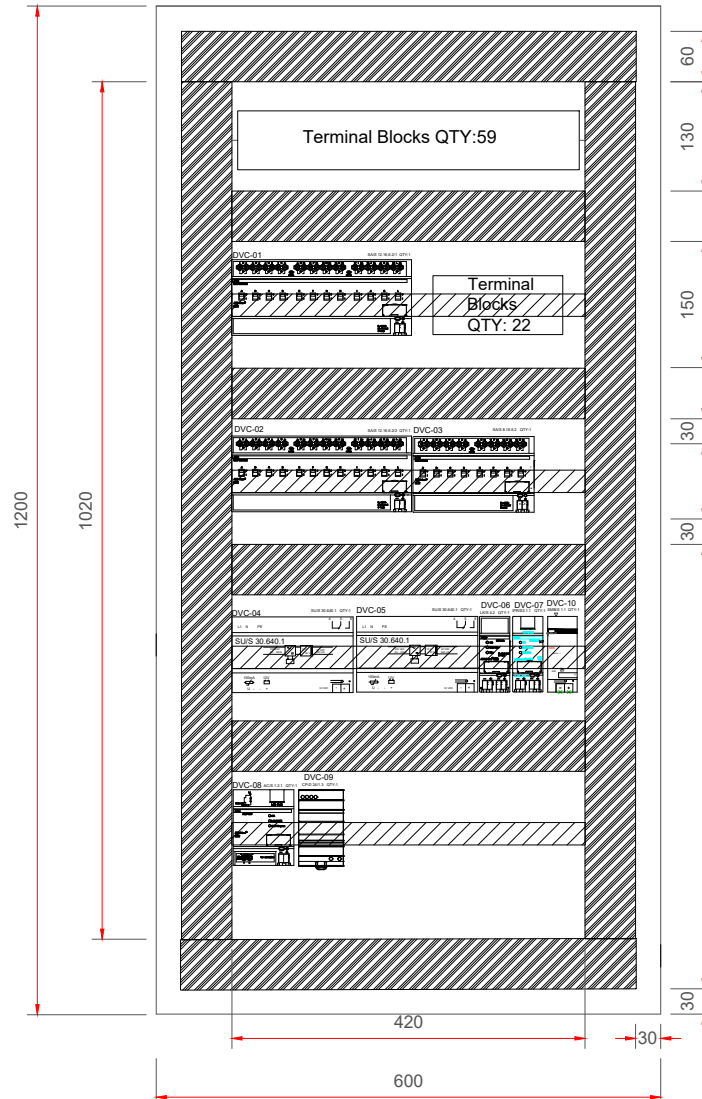

GENERAL NOTES:

System Integrator



OWNER:



CONSULTANT :



CONTRACTOR:



PROJECT TITLE:

HSBC Maadi Nile Courmich

DRAWING TITLE :

KNX PANEL SHOP DRAWINGS

DRAWING NUMBER :

DB-AG

PAGE: 1

PREPARED BY:	CHECKED BY:	APPROVED BY:	
ENG. M.E	ENG. M.T	ENG. M.H	
DATE	REV.	PROJECT NO.	PAPER
October-2023	00	--	A4

DVC-01

ADD: 2.2.1

SA/S 12.16.6.2/1 QTY:1

GENERAL NOTES:

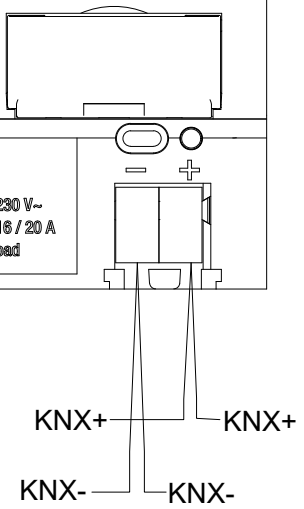
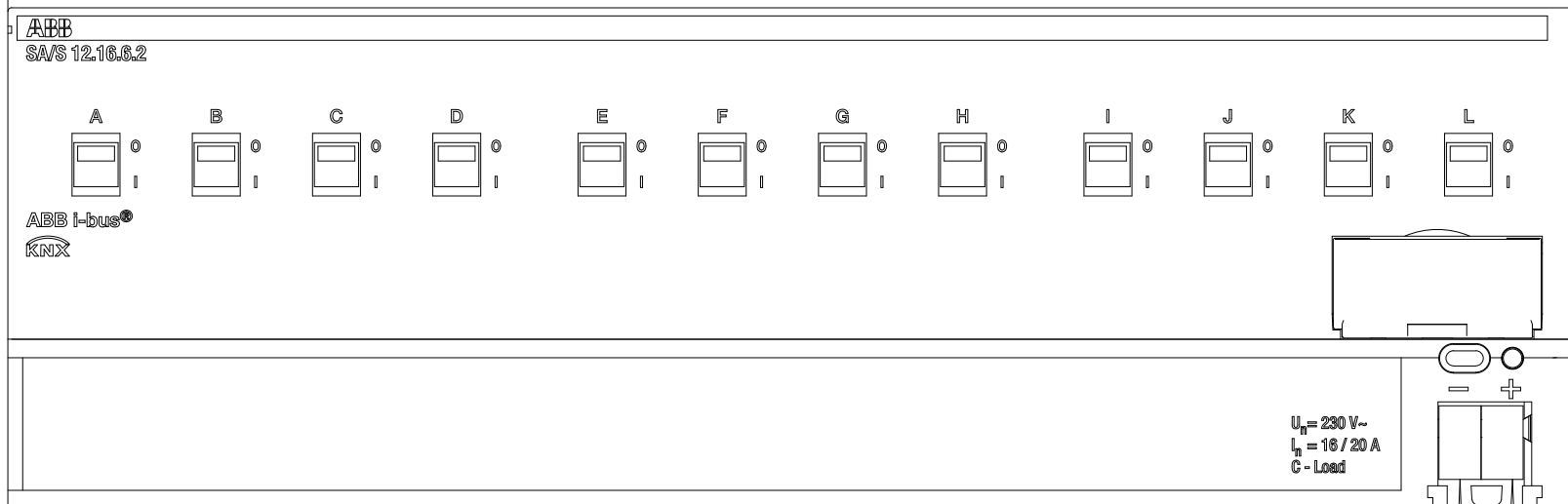
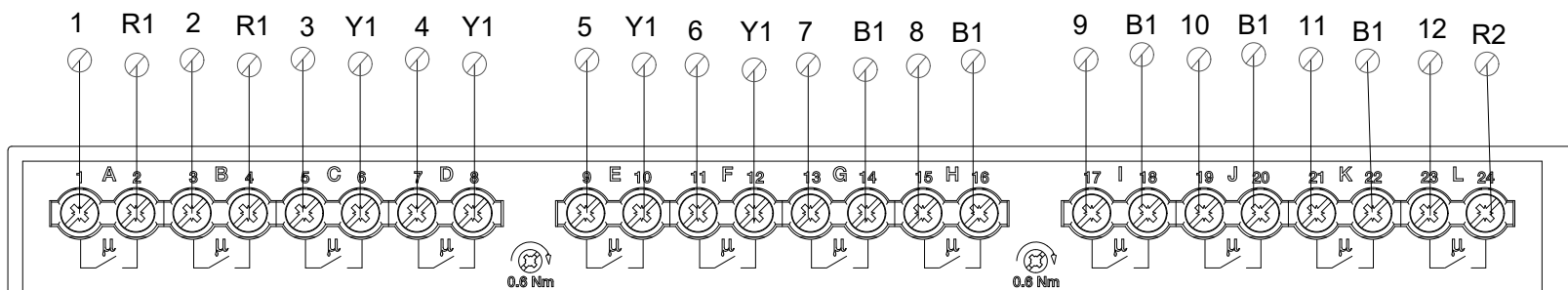

System Integrator

OWNER:

CONSULTANT:

CONTRACTOR:

PROJECT TITLE:
HSBC Maadi Nile Courmich

DRAWING TITLE :
KNX PANEL SHOP DRAWINGS

DRAWING NUMBER :
DB-AG

PAGE: 2

PREPARED BY:	CHECKED BY:	APPROVED BY:	
ENG. M.E	ENG. M.T	ENG. M.H	
DATE	REV.	PROJECT NO.	PAPER
October-2023	00	--	A4

DVC-02

SAS 12.16.6.2/2 QTY:1

ADD: 2.2.2

GENERAL NOTES:



ABB
 SAS 12.16.6.2



ABB I-bus®
 KNX

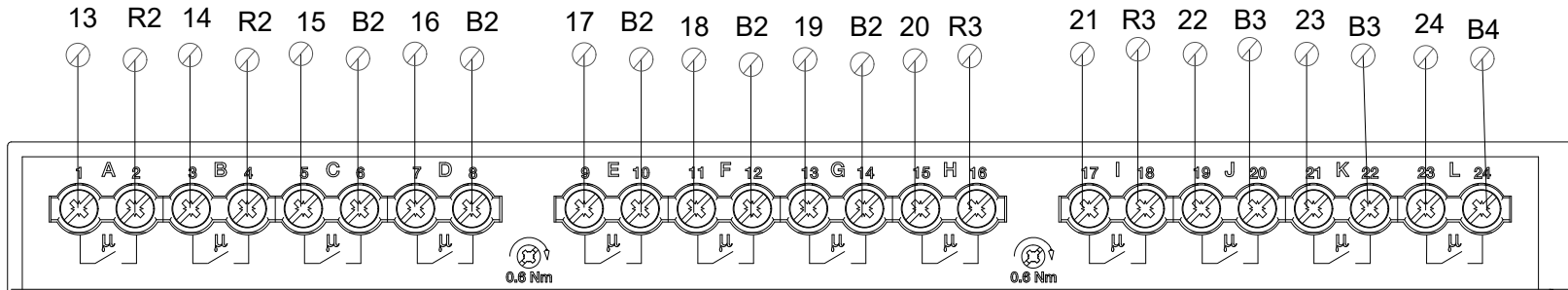

KNX+ ——— KNX+
 KNX- ——— KNX-

System Integrator

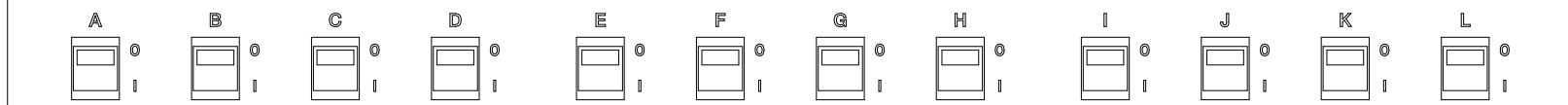
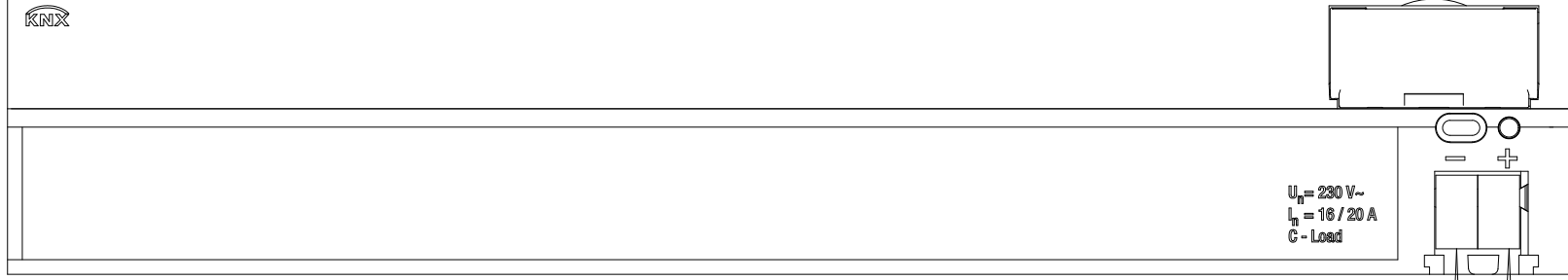
OWNER:

CONSULTANT:

CONTRACTOR:

PROJECT TITLE:
 HSBC Maadi Nile Courch

DRAWING TITLE :
 KNX PANEL SHOP DRAWINGS

DRAWING NUMBER :
 DB-AG
 PAGE: 3

DATE	REV.	PROJECT NO.	PAPER
October-2023	00	--	A4

DVC-03

SA/S 8.16.6.2 QTY:1

ADD: 2.2.3

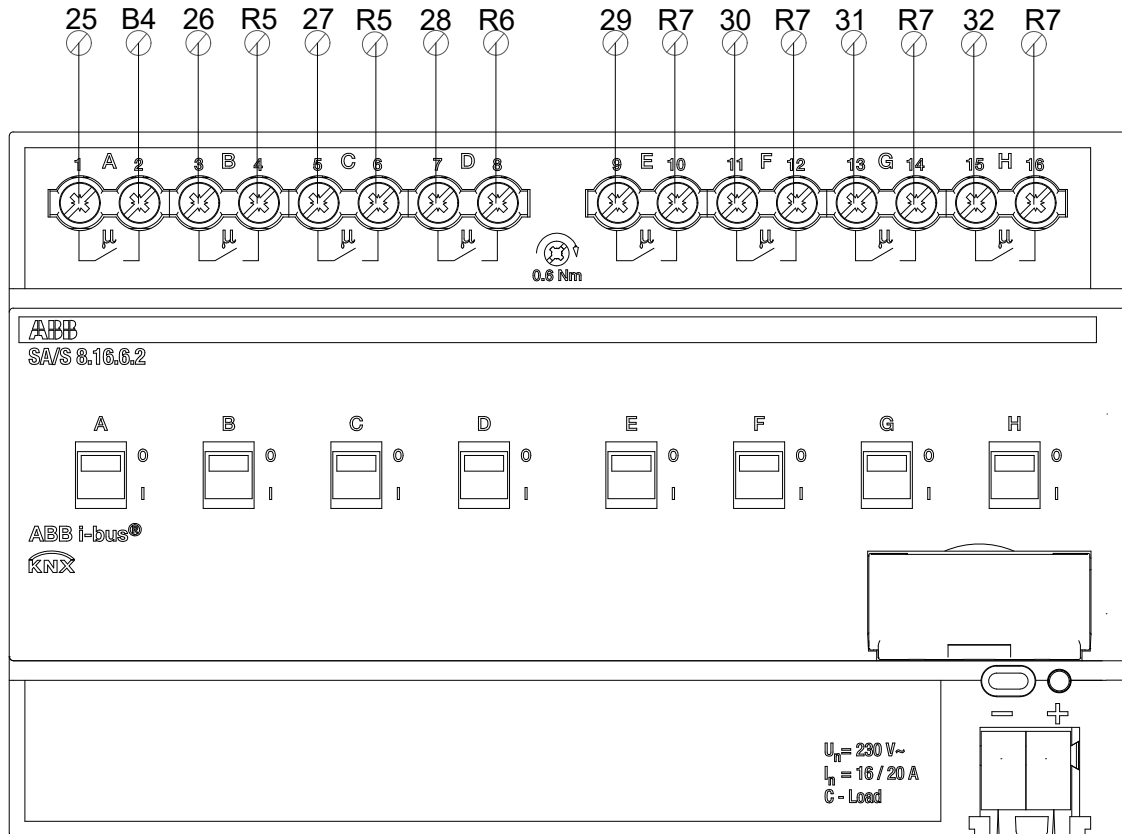

GENERAL NOTES:

System Integrator



OWNER:



CONSULTANT:



CONTRACTOR:



PROJECT TITLE:

HSBC Maadi Nile Courmich

DRAWING TITLE :

KNX PANEL SHOP DRAWINGS

DRAWING NUMBER :

DB-AG

PAGE: 4

DATE	REV.	PROJECT NO.	PAPER
October-2023	00	--	A4

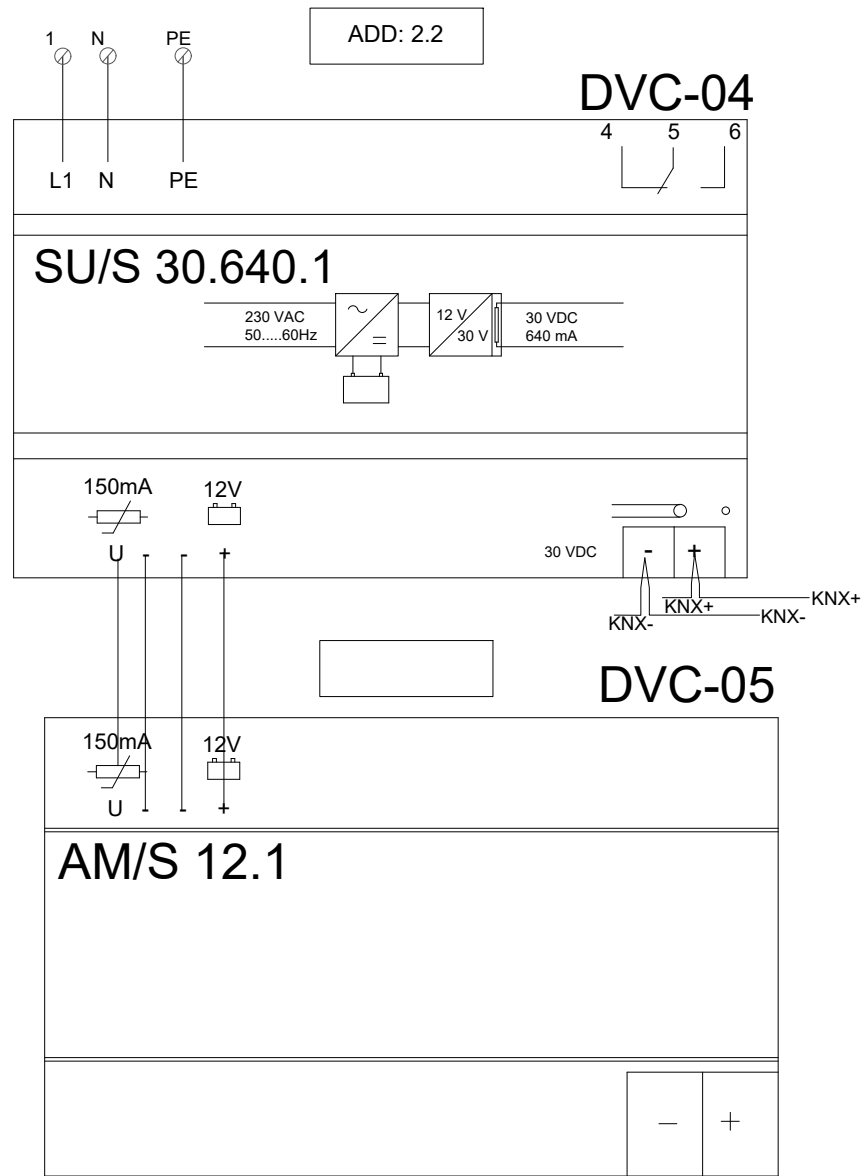

GENERAL NOTES:

System Integrator



OWNER:



CONSULTANT :



CONTRACTOR:



PROJECT TITLE:

HSBC Maadi Nile Courmich

DRAWING TITLE :

KNX PANEL SHOP DRAWINGS

DRAWING NUMBER :

DB-AG

PAGE: 5

PREPARED BY:	CHECKED BY:	APPROVED BY:	
ENG. M.E	ENG. M.E	ENG. M.H	
DATE	REV.	PROJECT NO.	PAPER
October-2023	00	--	A4

4
TY:1

ADD: 2.2.0

DVC-06

LK/S 4.2

ABB

- ON
- Main Line
- Line

1= Main Line
2= Line

U₀ = 12...30 V ===

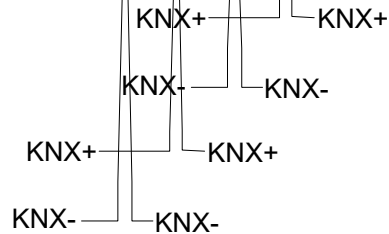
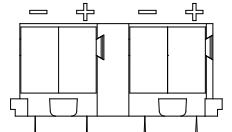

KNX+

GENERAL NOTES:

System Integrator



OWNER:



CONSULTANT :



CONTRACTOR:



PROJECT TITLE:

HSBC Maadi Nile Courmich

DRAWING TITLE :

KNX PANEL SHOP DRAWINGS

DRAWING NUMBER :

DB-AG

PAGE: 6

PREPARED BY:	CHECKED BY:	APPROVED BY:	
ENG. M.E	ENG. M.T	ENG. M.H	
DATE	REV.	PROJECT NO.	PAPER
October-2023	00	--	A4

DATA PORT



DVC-07

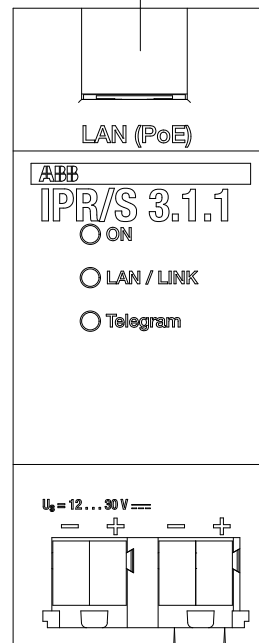

-12VDC
+12VDC
KNX+ KNX+
KNX- KNX-

GENERAL NOTES:

System Integrator



OWNER:



CONSULTANT :



CONTRACTOR:



PROJECT TITLE:

HSBC Maadi Nile Courmich

DRAWING TITLE :

KNX PANEL SHOP DRAWINGS

DRAWING NUMBER :

DB-AG

PAGE: 7

PREPARED BY:		CHECKED BY:		APPROVED BY:	
DATE	REV.	PROJECT NO.	PAPER	ENG. M.E	ENG. M.H
October-2023	00	--	A4		

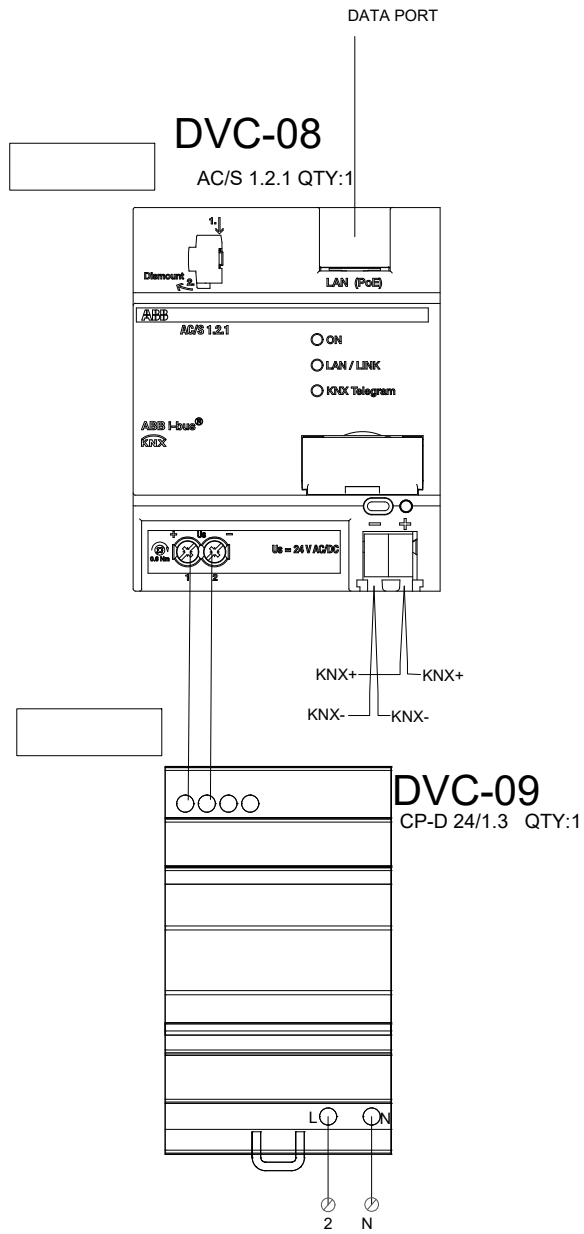

GENERAL NOTES:

System Integrator



OWNER:



CONSULTANT :



CONTRACTOR:



PROJECT TITLE:

HSBC Maadi Nile Courmich

DRAWING TITLE :

KNX PANEL SHOP DRAWINGS

DRAWING NUMBER :

DB-AG

PAGE: 8

PREPARED BY:		CHECKED BY:		APPROVED BY:	
ENG. M.E	ENG. M.T	ENG. M.T	ENG. M.H	ENG. M.H	ENG. M.H
DATE	REV.	PROJECT NO.	PAPER		
October-2023	00	--	A4		

DVC-04

SMB/S 1.1 QTY:1

N?

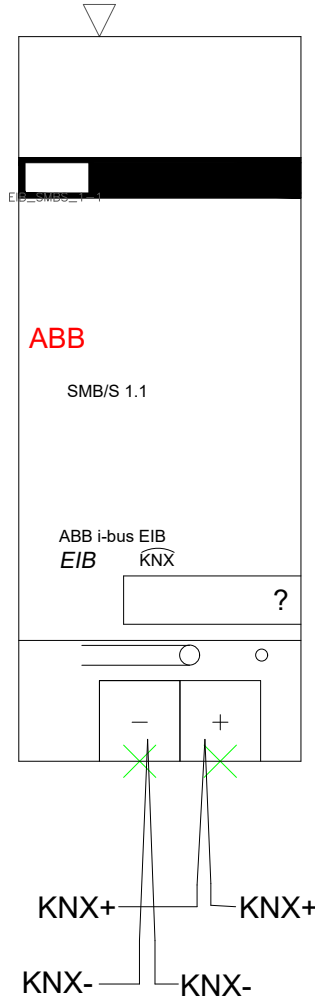

GENERAL NOTES:

System Integrator



OWNER:



CONSULTANT :



CONTRACTOR:



PROJECT TITLE:

HSBC Maadi Nile Courmich

DRAWING TITLE :

KNX PANEL SHOP DRAWINGS

DRAWING NUMBER :

DB-AG

PAGE: 9

DATE	REV.	PROJECT NO.	PAPER
October-2023	00	--	A4

K

HSBC

GROUND FLOOR

		NUMBER OF RETURNS CONTROLLED BY PRESENCE SENSOR ONLY / PIR & LIGHTING SWITCH / LIGHTING SWITCH ONLY	CIRCUIT COLOR	CIRCUIT NO.	RETURNS NO. FOR EACH CIRCUIT	LOCATION	NUMBER OF DALI LIGHTING FIXTURES (DALI DRIVER)	PRESENCE SENSOR	KEYPAD & TOUCH SCREEN	Actuator Address	Actuator Channel
DB-AG	32	R1	CT1	1	DRIVERS ROOM G-118	0	38	2 KEYPADS	DVC-01 2.2.1	A	
				2	FM ROOM G-117					B	
		Y1	CT2	3	MESS ROOM G-116	C					
				4	Male Shower G-115	D					
				5	Female Shower G-114	E					
				6	POST ROOM G-112	F					
		B1	CT3	7	EXISTING PS SECURITY G-149	G					
				8	FM House Keeping G-121	H					
				9	DISABLED TOILET G-148	I					
				10	Male Toilet Lobby	J					
				11	Male Toilet G-124	K					
		R2	CT4	12	ATM LAB G-105	L					
				13	PC Racks G-145	A					
				14	BUILDING SECURITY G-106	B					
		Y2	CT5	LIFE	IT RISER G-122	-					
				15	Circulation G-109	C					
		B2	CT6	16	SERVICE ENTRANCE G-111	D					
				17	Circulation G-110	E					
				18	Circulation G-110	F					
				19	Circulation G-120	G					
		R3	CT7	20	RECEPTION G-101	H					
				21	RECEPTION G-101	I					
				22	RECEPTION G-101	J					
		B3	CT9	23	8P MEETING ROOM G-102	K					
				24	8P MEETING ROOM G-103	L					
		B4	CT12	25	WAITING ROOM G-104	A					
				26	RECEPTION G-101	B					
		R5	CT13	27	RECEPTION G-101	C					
				28	PINS LIGHT RECEPTION G-101	D					
		R6	CT16	29	SPARE	E					
				30	SPARE	F					
				31	SPARE	G					
32	SPARE			H							

GENERAL NOTES:

System Integrator



OWNER:



CONSULTANT:



CONTRACTOR:



PROJECT TITLE:
HSBC Maadi Nile Courmich

DRAWING TITLE :
KNX PANEL SHOP DRAWINGS

DRAWING NUMBER :
DB-AG
PAGE: 11

PREPARED BY:	CHECKED BY:	APPROVED BY:
ENG. M.E	ENG. M.T	ENG. M.H
DATE	REV.	PROJECT NO.
October-2023	00	--
		PAPER
		A4

EDB-AG Ground Floor

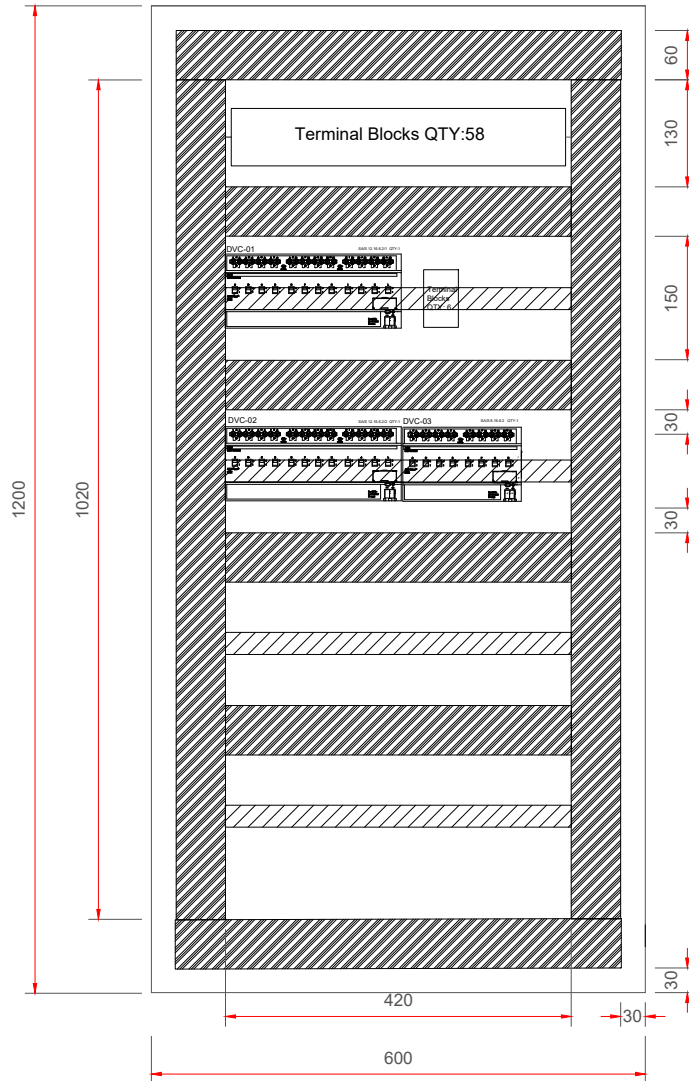

GENERAL NOTES:

System Integrator



OWNER:



CONSULTANT:



CONTRACTOR:



PROJECT TITLE:

HSBC Maadi Nile Coumich

DRAWING TITLE :

KNX PANEL SHOP DRAWINGS

DRAWING NUMBER :

EDB-AG

PAGE: 1

PREPARED BY:	CHECKED BY:	APPROVED BY:	
ENG. M.E	ENG. M.T	ENG. M.H	
DATE	REV.	PROJECT NO.	PAPER
October-2023	00	--	A4

DVC-01

SA/S 12.16.6.2/1 QTY:1

ADD: 2.2.4

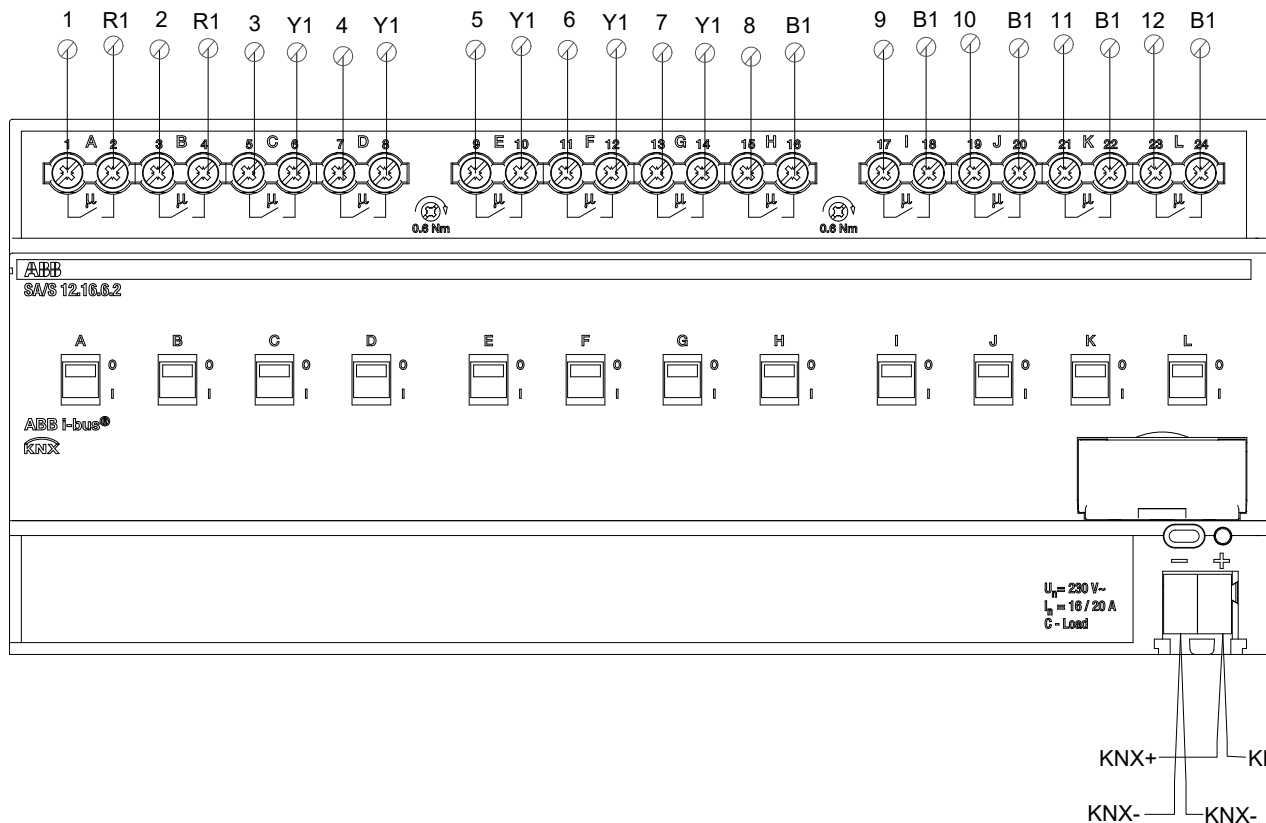

GENERAL NOTES:

System Integrator



OWNER:



CONSULTANT:



CONTRACTOR:



PROJECT TITLE:

HSBC Maadi Nile Courmich

DRAWING TITLE :

KNX PANEL SHOP DRAWINGS

DRAWING NUMBER :

EDB-AG

PAGE: 2

PREPARED BY:	CHECKED BY:	APPROVED BY:	
ENG. M.E	ENG. M.T	ENG. M.H	
DATE	REV.	PROJECT NO.	PAPER
October-2023	00	--	A4

DVC-02

SA/S 12.16.6.2/2 QTY:1

ADD: 2.2.5



ABB
SA/S 12.16.6.2



ABB i-bus®
KNX

$U_n = 230\text{ V-}$
 $I_n = 16 / 20\text{ A}$
C-Load

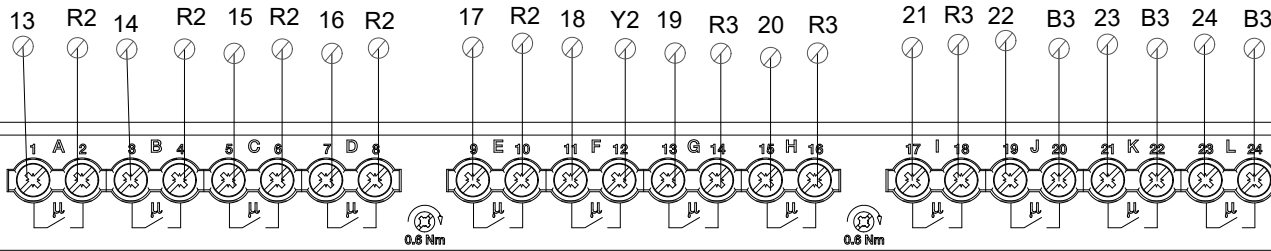

GENERAL NOTES:

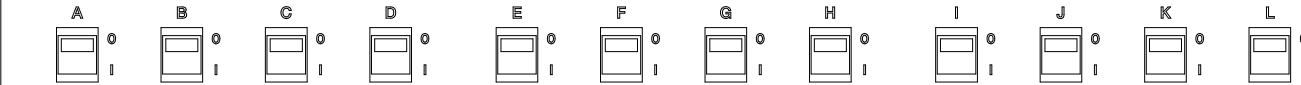
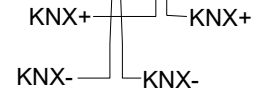
System Integrator



OWNER:



CONSULTANT:



CONTRACTOR:



PROJECT TITLE:

HSBC Maadi Nile Courmich

DRAWING TITLE :

KNX PANEL SHOP DRAWINGS

DRAWING NUMBER :

EDB-AG

PAGE: 3

DATE	REV.	PROJECT NO.	PAPER
October-2023	00	--	A4

DVC-03

S/S 8.16.6.2 QTY:1

ADD: 2.2.6

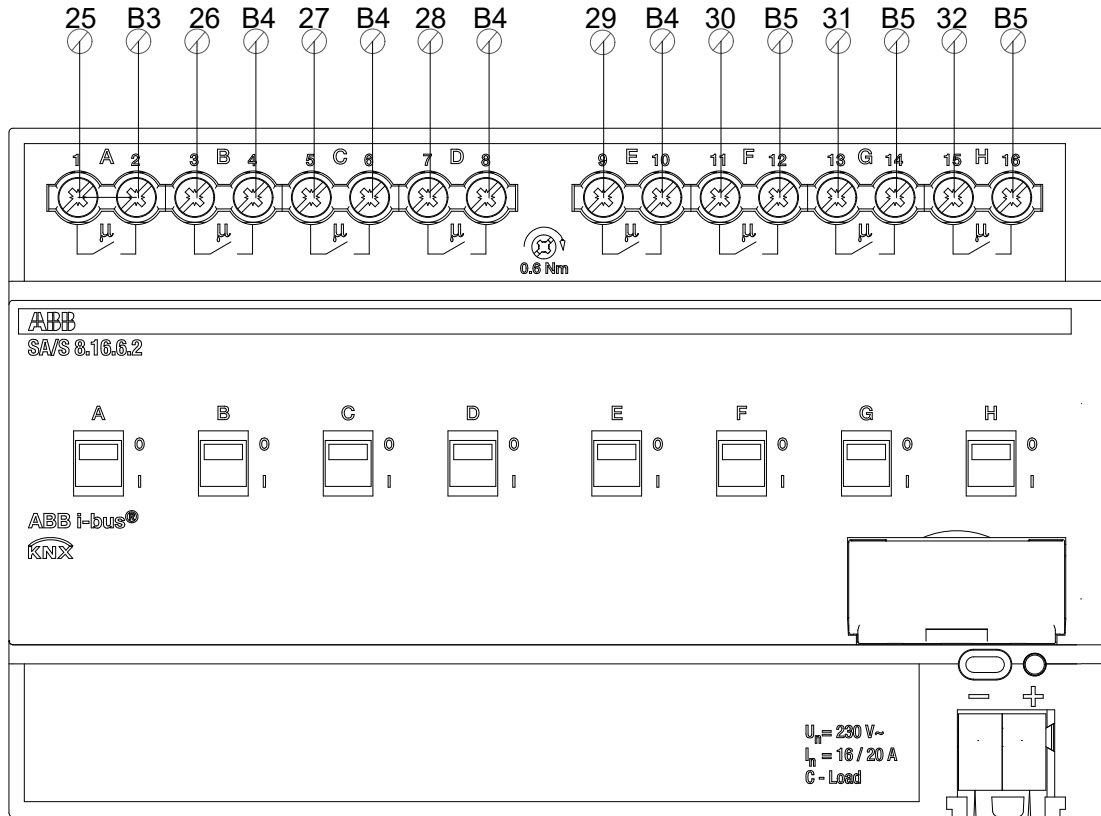

GENERAL NOTES:

System Integrator



OWNER:



CONSULTANT:



CONTRACTOR:



PROJECT TITLE:

HSBC Maadi Nile Courmich

DRAWING TITLE :

KNX PANEL SHOP DRAWINGS

DRAWING NUMBER :

EDB-AG

PAGE: 4

PREPARED BY:		CHECKED BY:		APPROVED BY:	
ENG. M.E	REV.	ENG. M.T	REV.	ENG. M.H	PAPER
October-2023	00	--	--		A4

HSBC

		NUMBER OF RETURNS CONTROLLED BY PRESENCE SENSOR ONLY / PIR & LIGHTING SWITCH / LIGHTING SWITCH ONLY	CIRCUIT COLOR	CIRCUIT NO.	RETURNS NO. FOR EACH CIRCUIT	LOCATION	NUMBER OF DALI LIGHTING FIXTURES (DALI DRIVER)	PRESENCE SENSOR	KEYPAD & TOUCH SCREEN	Actuator Address	Actuator Channel
GROUND FLOOR	EDB-AG	32	R1	CT1	1	DRIVERS ROOM G-118	0	38	2 KEYPADS	DVC-01 2.2.4	A
					2	FM ROOM G-117					B
			Y1	CT2	3	MESS ROOM G-116	C				
					4	POST ROOM G-112	D				
					5	Pins Print G-113	E				
					6	Female Shower G-114	F				
					7	Male Shower G-115	G				
			B1	CT3	8	EXISTING PS SECURITY G-149	H				
					9	FM House Keeping G-121	I				
					10	DISABLED TOILET G-148	J				
					11	Male Toilet Lobby	K				
					12	Male Toilet G-124	L				
			R2	CT4	13	ATM LAB G-105	A				
					14	PC Racks G-145	B				
					15	BUILDING SECURITY G-106	C				
					16	ELEC ROOM G-107	D				
			Y2	CT5	17	STAIRS LOBBY G-108	E				
					18	STAIRS G-147	F				
					19	RECEPTION G-101	G				
			R3	CT7	20	RECEPTION G-101	H				
					21	RECEPTION G-101	I				
					22	Circulation G-109	J				
			B3	CT9	23	SERVICE ENTRANCE G-111	K				
					24	Circulation G-110	L				
					25	Circulation G-120	A				
			B4	CT12	26	WAITING ROOM G-104	B				
					27	8P MEETING ROOM G-103	C				
					28	8P MEETING ROOM G-102	D				
					29	RECEPTION G-101	E				
						30	SPARE			F	
						31	SPARE			G	
						32	SPARE			H	

GENERAL NOTES:

System Integrator



OWNER:



CONSULTANT:



CONTRACTOR:



PROJECT TITLE:
HSBC Maadi Nile Courmich

DRAWING TITLE :
KNX PANEL SHOP DRAWINGS

DRAWING NUMBER :
EDB-AG
PAGE: 6

PREPARED BY:	CHECKED BY:	APPROVED BY:
ENG. M.E	ENG. M.T	ENG. M.H
DATE	REV.	PROJECT NO.
October-2023	00	--
		PAPER
		A4